

# DEVELOPMENT OF AN EFFECTIVE SCHEME OF OPERATION OF VOLUMETRIC HYDROURITMA IN HYDRAULIC SYSTEMS OF MINING MACHINES

Turdiyev Sardorjon Abdumuminovich

PhD, Acting Associate Professor of the "Exact, Technical and Natural Sciences", Navoi University of innovation, PhD.

e-mail: sardor\_kem@mail.ru

Akhmedov Soyibjon Tojiboyevich

Assistant of the Department of "Mining Electrical Mechanics" of the Navoi State University of Mining and Technologies

Salimova Shahrizoda Sanjar qizi

Student of the Department of Mining Electromechanics, Navoi State Mining and Technology University

## Abstract

It is now widely used in mining, construction and agriculture with a hydraulic system from a number of machines and equipment. In order to increase the stable and reliable operation of hydraulic systems of these machines, it is important to develop the correct prinspial schemes for them, this article presents analyzes on the basis of the development of the prinspial scheme of hydraulic operation of volumetric pumping devices.

**Keywords:** pump, drive, prinspial circuit, hydraulics, machine, equipment, control devices, hydromotor, hydrosilindr.

## Introduction

Hydraulic propulsion is a set of hydraulic machinery, hydraulic equipment, hydrolines (tubes), and auxiliary devices, called a hydraulic system designed to transfer energy and convert motion through fluid. At the same time, regulating and reversing the speed in the output device, as well as transferring one type of movement to another, can be carried out simultaneously[1,2].

Hydraulic machines that are part of hydraulic operation are pumps and hydrodvigatels, which can be several.

Hydraulic devices are hydraulic drive control devices with which it is regulated, as well as means of protecting it from high and low pressures of fluid. Hydraulic device equipment also includes drossels, valves for various purposes, and distribution devices for changing the direction of hydraulic fluid flow[3].

Auxiliary devices are called air conditioners of the working fluid, which serve to ensure its quality and condition. These are various particle separators (filters), heat exchangers (heaters and coolers), hydrobags and accumulators[4].



Hydraulic Yaw elements are connected to reciprocating working fluid driven hose hydrolines.

**LITERATURE ANALYSIS AND METHODOLOGY**

Let's consider the structure scheme of the simplest porcelain hydraulic drive in Figure 1.

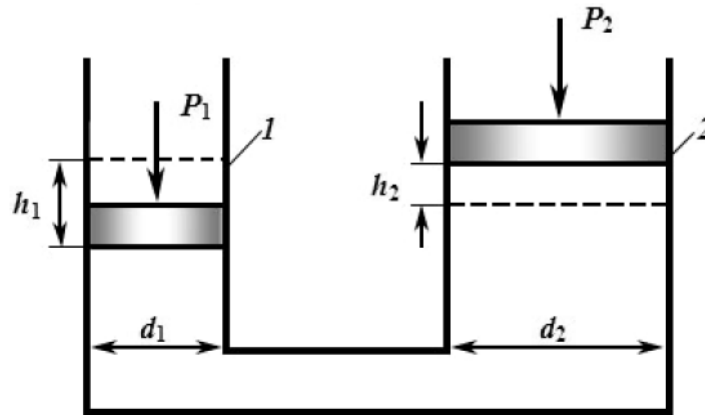

**Figure 1. The structure scheme of the simplest porcelain hydraulic circuit**

The two cylinders (1 and 2) are filled with liquid and connected to each other by a straight tube. With the  $P_1$  force supplied from the top of the 1st cylinder piston, the  $h_1$  slides down the distance and releases the liquid into the 2nd cylinder. In this case, the cylinder 2 piston  $h_2$  carries the distance up and carries the  $P_2$  load up[5,6].

If we ignore pressure losses (hydraulic losses and friction losses), then according to Pascal's law, the pressure generated by the force  $P_1$  in cylinder 1 will be equal to the entire volume of the fluid:

$$p_1 = \frac{P_1}{F_1} = \frac{P_2}{F_2} = p_2.$$

here,  $F_1$  and  $F_2$  are the surfaces of the 1 and 2 cylinder porches.

Then the relationship ratio between the pressure forces acting on the porches will be as follows[7]:

$$P_2 = P_1 \left( \frac{d_2}{d_1} \right)^2.$$

The liquid can be considered almost incompressible and the cylinders completely hermetized.

$$h_1 F_1 = h_2 F_2$$

here,  $h_1$  and  $h_2$  are the displacement rates of the porches.

The power dependence exerted on the motion of the porcelain in cylinder 1 is determined by the expression[8]:

$$N = P_1 v_1 = p_1 F_1 v_1.$$

In the above formula, the product of speed and consumption gives the consumption  $v_1 F_1 = Q$ .



Then the law of conservation and transfer of energy (in the absence of hydraulic losses and frictional forces) takes the form [9]:

$$P_1 v_1 = p Q = P_2 v_2. \quad (1)$$

here,  $P_2 v_2 - 2$  is the power developed by porshen, that is, an indicator that expresses the dependence of the system assigned to the unit of time on the output device.

From the above Formula (1), it follows that increasing the hydraulic drive force is more useful not by increasing the area of the porches (which leads to an increase in dimensions), but by increasing the pressure, since in this case a slight increase in the volume and weight of the hydraulic drive is caused by the need to increase its power [10,11].

## RESULTS

Depending on the purpose of the hydraulic system and in accordance with the selected variant of the initial given data, it is necessary to draw up a sketch of the prinsipial scheme of the hydraulic drive, which will then be tested and determined by calculations. In the scheme, all elements of the equipment necessary for its operation are used. Signs of elements are accepted in accordance with regulatory documents [12,13,14].

Next, you need to choose a method of regulating the speed of hydraulic drive in the output link: drosselli (Figure 1) or volumetric (Figure 2) [15].

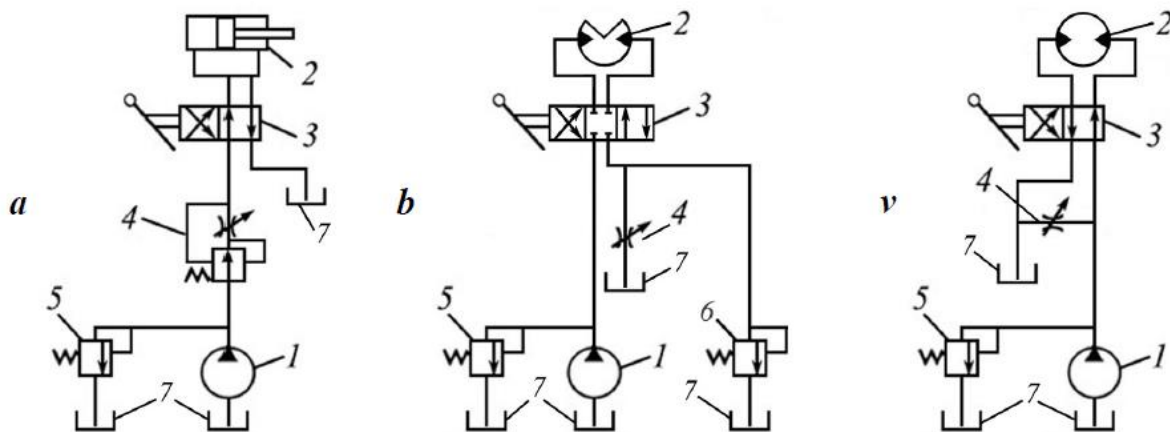

**Fig.1. Throttle regulation hydraulic system:**

*1 – pump; 2 - hydraulic motor (a - power hydraulic cylinder; b - moment hydraulic cylinder; v - hydromotor); 3 – distribution device (a – two-stage; b – three-stage); 4 – throttle regulator; 5 – overflow valve; 6 – safety valve; 7 – pouring tube.*

In this case, it is necessary to analyze the aspect of technical and economic efficiency. Throttle controlled hydraulic systems are relatively easy and inexpensive to operate. However, due to large energy losses, the throttle regulation method is currently used in low-power hydraulic systems ( $N < 15$  kW) in production conditions [16,17].

By installing a throttle in the main pressure pipeline, a series throttle arrangement is implemented (Fig. 1,a) and is used in cases where there is a load of one sign at the output link.

When there is a variable load or large accelerations of the output link, a regulating throttle should be installed in the main pipeline (Fig. 1, b).

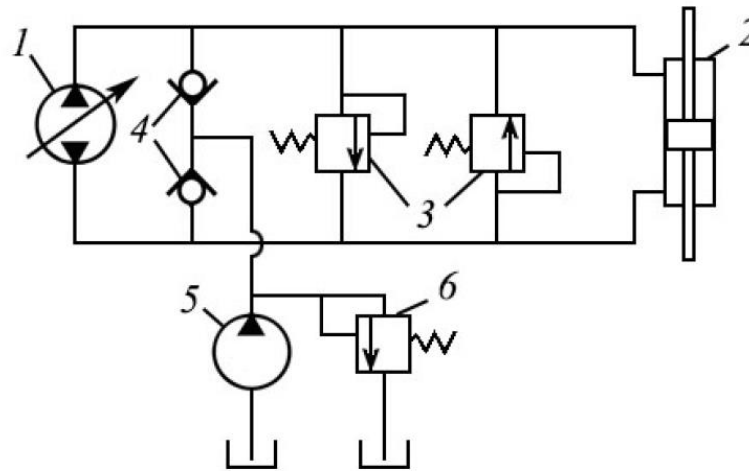

**Fig.2. Volume regulation hydraulic system:** 1 – regulating pump; 2 – power hydraulic cylinder; 3 – safety valve; 4 – reverse valve; 5 – auxiliary pump device for supplying the system; 6 - overflow valve.

The parallel throttling regulation method (Fig. 1.v) has a higher efficiency than the series throttling method, so it can be used with relatively high power requirements (from 10 to 15 kW). However, the disadvantages of such a hydraulic system are a decrease in external network characteristics, regulation accuracy and stability.

Regulation with a hydraulic driving power of more than 15 kW, despite the relatively high price of the hydraulic machine, it is necessary to adopt the volumetric regulation method (Fig. 2).

## DISCUSSION

The choice of the regulation method can be made by the output power of the hydraulic system in the following cases:

- in hydraulic motors and torque hydraulic cylinders:

$$N = M_{st}w$$

- in force hydrosylindres:

$$N = R_{st}v$$

The value of the magnitude of the angular velocity:

- for hydromotor valve:

$$w = \frac{2\pi n}{60}$$

- for hydrosilindre moment:

$$w = \frac{\varphi}{t} \frac{2\pi}{60}$$

- Hydrosilindr shtok action rate:

$$v = \frac{s}{t}$$

## CONCLUSION

Based on the above analysis and results, when developing the principle scheme of the hydraulic system, the total load on it consists of static and inertia and is determined as follows:

- for hydraulic motors and torque hydraulic cylinders:

$$M = M_{st} + M_{in} ;$$

- for power hydraulic cylinders:

$$R = R_{st} + R_{in} .$$

The value of the moment of inertia load  $M_{in}$  is determined by the expression:

$$M_{in} = J \varepsilon ,$$

where,  $J$  – is the moment of inertia of the moving parts on the output shaft;

$\varepsilon$  – is the angular acceleration of the shaft.

The angular acceleration of the shaft is determined as follows:

$$\varepsilon = \frac{\omega}{t'}$$

where,  $t'$  - the time to enter the mode is assumed to be equal to one tenth of the duty cycle (0.1 t), but not more than 1 second.

The magnitude of the inertial force is determined by the following formula:

$$R_{in} = m a ,$$

where,  $m$  – the weight of the rotating parts of the hydraulic cylinder;  $a = \frac{v}{t}$  - acceleration in the compression link.

We can see that the volume pumping devices of the hydraulic system depend on a number of indicators, which are necessary to justify the development of the principle scheme of the hydraulic system. On the basis of the above results, the principle scheme of volumetric hydraulic treatment will be built, and through this principle scheme, it will be possible to ensure the operation of hydraulic treatment at optimal efficiency.

## REFERENCES

- Turdiyev , S. A., & Akhmedov , S. T. (2023). FUNDAMENTALS OF EXTERNAL NETWORK CHARACTERISTICS OF HYDRAULIC SYSTEM. *Educational Research in Universal Sciences*, 2(1 SPECIAL), 87–93.
- Turdiyev, S. A. (2023). *GIDRAVLIK YURITMANING TASHQI TARMOQ TAVSIFINI HISOBLASHNI ASOSLASH*. *Innovative Development in Educational Activities*, 2(5), 327–333.
- Azamatovich, A. N., Shavkatovich, Z. A., Abdumuminovich, T. S., & Xusniddinovich, A. S. (2005). Simulation of the Motion of Dusted Air Flows Inside the Air Filter of a Hydraulic System of a Quarry Excavator. *International Journal of Grid and Distributed Computing (IJGDC)*, ISSN, 4262, 11-18.



4. Turdiyev, S. A., and Jurayev A. Sh. "Study of the effect of excavator bucket tooth abrasion on digging resistance." *Academic Research in Education Sciences* 3.3 (2022): 105-110.
5. Абдуазизов, Набижон Азаматович. "Турдиев Сардоржон Абдумуминович Жураев Акбар Шавкатович. Разработка математическая модель тепловых процессов в регулирующем контуре гидрообъемной силовой установки карьерного комбайна (44-47)." *Евразийский Союз Ученых. Технические науки* 62.1 (2019): 44-47.
6. Djuraev, R. U., and S. A. Turdiyev. "Mathematical modeling of the wear of cutting elements on quarry excavators." *International journal of advanced research in science, engineering and technology (IJARSET)–India* 9.3 (2022): 19074-19080.
7. Мустафаев О.Б., Турдиев С.А. ДИНАМИЧЕСКОЕ ВОЗДЕЙСТВИЕ РЕЗЦОВ ИНСТРУМЕНТАМИ РЕЖУЩЕ-СКАЛЫВАЮЩЕГО ДЕЙСТВИЯ.
8. Azamatovich, A. N., Shavkatovich, Z. A., Abdumuminovich, T., & Khusniddinovich, A. (2005). Modeling the movement of dusty air flows inside the air filter of the hydraulic system of a mining excavator. *International Journal of Grid and Distributed Computing (IJGDC)*, ISSN, 4262, 11-18.
9. Abdumuminovich T. S., Tojiboyevich A. S. ANALYSIS OF EFFICIENCY OF CONTROL METHODS OF HYDRAULIC DRIVE MOTORS //RESEARCH AND EDUCATION. – 2023. – Т. 2. – №. 2. – С. 109-115.
10. Abduazizov N. A. et al. Hidroekskavatorning gidrobakdagi havo filtrining ichida changlangan havo oqimlari harakatini modellashtirish //Academic research in educational sciences. – 2021. – Т. 2. – №. 3. – С. 294-304.
11. Abdumuminovich T. S., Tojiboyevich A. S. GIDRAVLIK YURITMALARNI TARTIBGA SOLISH USULLARI SAMARADORLIGINI OSHIRISH //Journal of Integrated Education and Research. – 2023. – Т. 2. – №. 2. – С. 8-14.
12. Raykhanova G. Y., Djuraev R. U., Turdiyev S. A. DEVELOPMENT AND EXPERIMENTAL RESULTS OF A NEW CONSTRUCTION OF THE ELEMENT OF PROTECTION OF THE BASE OF THE JAVE PART OF QUARRY EXCAVATORS //The American Journal of Engineering and Technology. – 2022. – Т. 4. – №. 04. – С. 58-67.
13. Turdiyev S. A., Djuraev R. U. Experimental results on the effectiveness of an improved excavator bucket tooth design //The American Journal of Engineering and Technology. – 2022. – Т. 4. – №. 03. – С. 1-13.
14. Turdiyev S. A. et al. Experimental and test study of the effectiveness of the improved design of the excavator bucket jaw plate //Central Asian Research Journal for Interdisciplinary Studies (CARJIS). – 2022. – Т. 2. – №. 3. – С. 214-223.
15. Кахаров С. К., Турдиев С. А., Аблакулов С. Б. Увеличение ресурса бурового оборудования, за счет применение структурно-функциональной схемы ремонта взаимосвязанных элементов //Современные научные исследования и разработки. – 2018. – Т. 1. – №. 5. – С. 329-332.
16. Xalilov S., Raxmatova Z., Raxmatova F. GIDRAVLIK EKSKAVATORNING EKSPLOATATSION XARAJATLARINI TAHLILI //Zamonaviy dunyoda pedagogika va psixologiya: Nazariy va amaliy izlanishlar. – 2022. – Т. 1. – №. 26. – С. 34-39.



17. Abdullayev, S. H. ., Turdiyev, S. A. ., Raxmatova , Z., & Raxmatova , F. . (2022). KON MASHINALARI GIDRAVLIK TIZIMINING HAVO FILTRINI TAKOMILLASHTIRISH. Journal of Integrated Education and Research, 1(4), 417–423.
18. Raykhanova G. Y., Djuraev R. U., Turdiyev S. A. DEVELOPMENT AND EXPERIMENTAL RESULTS OF A NEW CONSTRUCTION OF THE ELEMENT OF PROTECTION OF THE BASE OF THE JAVE PART OF QUARRY EXCAVATORS //The American Journal of Engineering and Technology. – 2022. – T. 4. – №. 04. – C. 58-67.
19. Raykhanova G. Y., Dzhuraev R. U., Turdiyev S. A. STUDY OF THE LOADS ON BUCKETS AND CUTTING ELEMENTS OF QUARRY EXCAVATORS DURING DIGGING AND CUTTING //Academic research in educational sciences. – 2022. – T. 3. – №. 4. – C. 1123-1132.